

HauntMaven.com - Wolfstone's Haunted Halloween Site



http://wolfstone.halloweenhost.com/ThunderAndLightning/clsint_LightningSimulation.html

Thunder and Lightning



A haunted graveyard?

What's a haunted graveyard without thunder and lightning? Nothing, I tell you. It is just some land with overgrown grass - brown and dried grass - and some tombstones. That's all. That, and bats. Bats and ghouls, maybe. Oh, it might have a grave jumper, and a few vampires, but that's *it*. Well, maybe a flying crank ghost.

OK, without thunder and lightning you might still have a lot of stuff in your graveyard. Neat stuff, and really spooky. It might even kick ectoplasm, but to add that ultimate touch of otherworldliness, *you need thunder and lightning*. Unfortunately, Mother Nature seldom provides electrical storms exactly when the Trick Or Treaters queue up at the mausoleum. So we'll have to fake it.

Lightning is raw power, and we can sense it. It appears in flashes of light that are sometime bright enough to blind us, and is accompanied by sharp cracks of sound, booms, or sometimes a low rolling sound like the growling of an immense dragon. It is unpredictable and it is dangerous. For all these reasons, all of us have a core that loves and fears lightning.

There are devoted fans of thunder and lightning, chasing storms to see the beauty of silvery forked streaks from heaven. Some carry cameras, tape recorders, and other instruments. Those are the people who give in to a fascination that we all share, somewhere deep within us. You might analyze it scientifically, but lightning reaches us all on a primitive, emotional level. *That's* why you need lightning in your haunted graveyard.

Devotees of the science and beauty of real lightning would be horrified to know that we plan to fake some thunder and lightning in our graveyard. Speaking as a haunter, horrified is a *good* thing.



Adding Lightning To Your Haunt

There are various ways to add thunder and lightning to your haunt. All attempt to address the central problems of:

1. Providing realistic and loud thunder sounds
2. Providing convincing flashes of bright light
3. Synchronizing sound and light to imitate the natural phenomena.

There are numerous ways to achieve this effect. We will examine a few of the simplest good methods, touch on some other clever methods, and then discuss additional options.

Basic Approaches

There are three general approaches to generation of bogus thunder and lightning:

- Use a recording scheme that provides two or more tracks of information. Put the thunderstorm on one and use another to trigger flashing lights.
- Use a computer or pseudorandom sequence generator to decide when to fire a thunder/lightning strike.
- Start with the recorded sounds of a thunderstorm. During playback, synchronize a flashing light to the loud parts of the sound track (thunder claps).

We will touch lightly on the first two approaches. The bulk of this page will study various schemes whereby light flashes can be created in reasonable synchronization with an existing sound track of thunder noises.

Approach 1 - Multitrack Recording

The ultimate in lightning generation is the use of multiple recording tracks to create a multimedia presentation combining sound and synchronized lights.

The multi-track recording scheme is amazingly versatile, because just about any media capable of recording sounds and another track of control information can be used. One could use old 8-track tapes, video cassettes, endless-loop audio cassette tapes, compact disks, or computerized multimedia players.

Start by looking for a good audio recording of a thunderstorm. Check out the CD selection at your local music merchant. Look in the relaxing environmental sounds area. You might also look for a sound effects section. Try to listen before you buy, because some relaxation audios just don't have enough loud lightning strikes.

Once the audio track is set, the artist plays back the recording and decides exactly where during the performance lightning should happen. He then places a signal on the control track triggering the event.

The sophistication of these schemes varies as to the method used to implement the control track. In a high tech implementation, the control channel might be a digital track with exotic control information for various effects: lift the skeleton's head a little; make him point at the visitors; hit the lightning now!

The middle path would use another audio channel onto which one records special audio tones, such as the DTMF codes used by touch-tone telephones. During playback, the control tones are fed into a decoder, which triggers the lightning strokes.

A lower tech approach would be to paste pieces of aluminum foil on the back of the audio tape, sensing these trigger points with circuits that look for the shiny spot, or feel for the electrically conductive area. If you are strapped for cash, this approach might be the best, starting with an 8-track tape deck bought for \$5 from a garage sale.

One clever halloween-1 subscriber imported a thunder track into his computer's multimedia composition program and created a movie with white screens for lightning flashes. During his haunt, he just put a big video monitor outside the window. You can be assured that this fellow got exactly the kind of lightning he wanted, when and where he wanted it. That's because he handcrafted every second of his thunderstorm!

The chief drawback of the multi-track scheme is that you need artistic skill and patience to create the presentation, as well as the equipment to carry it off.

Personally, I tend to prefer fake lightning that starts with a commercial sound track for the thunder, and uses some kind of gadget to synchronize lightning flashes to that.

Approach 2 - Computer Control

It is a lot of work, but you can get excellent results by using a tiny computer to fire off lights and recorded thunder sounds.

One example of this method is the rig that Gary Van Balen built. It uses a Basic Stamp II SX computer (BS2SX) to trigger a 20-second sound chip and a strobe light. You can find Gary's setup at

http://homepage.mac.com/GaryVanBalen/s_StormFX.html  

Approach 3 - Synchronizing lights to an existing sound track

Perhaps the easiest way to get good lightning is to start with an existing sound track and synchronize lights to it.

Method 1 - Color Organ

A "color organ" is a device that flashes lights in time with music. They were popular in the psychedelic era, and constituted a type of light show before LASERs and optical fibers became cheap enough to be used for that sort of thing. They usually have several channels, each one sensitive to a different part of the audio spectrum. So low notes might flash a blue light, mid notes might light up yellow, and high notes might flash a red light. For each channel, the louder the sound, the brighter the light.

The application of a color organ to simulating lightning is obvious - if a box can flash a bright light when it hears a loud sound, that's all it takes to create lightning to match a canned sound track. You find a tape or CD with the sounds of a thunderstorm, play it nice and loud, and pipe the sounds into the color organ, which is also attached to a big light bulb. When the sound of the thunder crash is heard, the increased volume will cause the lamp to light up brightly. When the sound dies away, the lamp goes out. The color organ will have a "sensitivity" control, which you will have to adjust so that the lamp does not flicker while the audio track makes sounds of wind rain, and mild rumbling echoes.

You could use a single-channel color organ for lightning, feeding into a single large incandescent light bulb. I prefer to use at least a dual-channel color organ feeding two lamps. With each channel set to a different sensitivity level and watching a different portion of the audio spectrum, the lamps flash at slightly different times, making the lightning seem to move.

Color organs are a bit harder to find than they once were. Nowadays the folks at Radio Shack usually give you a blank stare if you ask for such a thing. Back in the 70s, every Radio Shack store had a couple of color organs on display in the store, and if you asked about one, the

salesman would not only be glad to sell you one, he would probably offer you some primo weed. Those days are gone. >sigh<

A color organ consists of a few simple functional areas:

- Input processing - Takes the sound from a microphone, your stereo speakers, or "line input" and prepares it for further use. This usually means amplifying it.
- Filters - Each channel should respond to a different part of the audio spectrum. Each channel has a filter that only allows the selected audio frequencies into that channel. Some color organs have sophisticated filters that can precisely select a desired frequency band. Cheaper color organs use inexpensive filters which aren't terrible selective. Such units provide a poor light show, but work fine for lightning.
- Drivers - This is the part of the circuit that actually turns the lamp on and off in response to the filtered signal.

Circuit diagrams for color organs are not difficult to find, but they are also inexpensive to buy already built — if you can find one. One particular unit is so inexpensive that you would spend a lot *more* money trying to build it from scratch. It consists of only the assembled and tested electronics board. In order to make the unit usable, you will need a power cord for it, a couple of outlets, two knobs, and some sort of insulated case to put it in.

WARNING — Wiring up the color organ board into a completed unit requires some skill with electronics. Since the circuit uses line voltage, it is potentially hazardous. If you are not qualified to do work of this sort, find somebody who is.

I originally found this unit in the catalog of [Electronic Goldmine](#). The stock number is G3319, with a regular price of \$5.95, and sometimes on sale for as low as \$3.95. The unit is advertised as driving up to 200 Watts per channel. It contains a built-in microphone, so you don't need to wire it to your sound system, just place it near one of your thunder speakers. I haven't seen this unit in the Goldmine catalog recently, but they might still have some in stock.

A similar, if not identical, color organ is sold by [Herbach & Rademan](#) as item number TM93ADV2347 — Color Organ; Sound Activated Light Show Board - \$4.95. The picture in the H&R catalog appears identical to the Electronic Goldmine unit, and the specifications are almost so: the H&R unit is quoted as handling only 100 Watts per channel.

The board from Electronic Goldmine does not include a schematic diagram. I have traced it out, and it looks something like this: [Note - Do not use this schematic to build a unit from scratch. You will spend a lot more money than if you just bought the board. In addition, this schematic might contain inaccuracies. This is just to give you an idea of what's going on.]

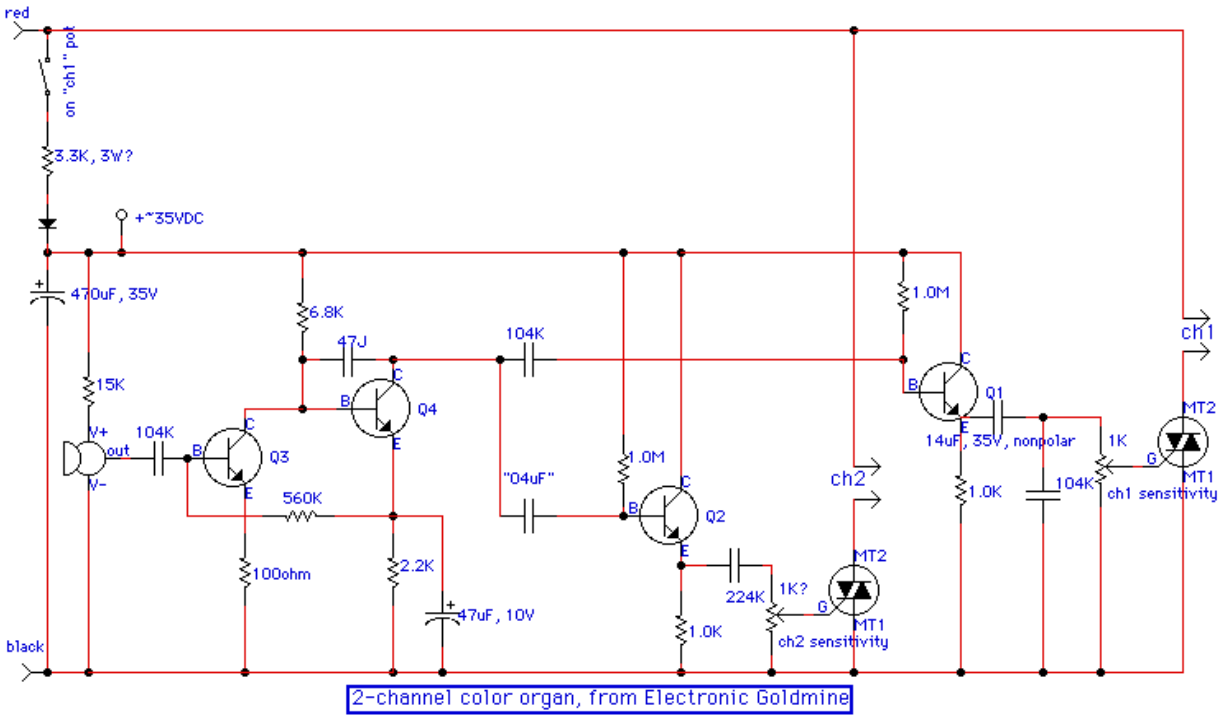

The sounds are detected by the FET microphone and amplified by transistors Q3 and Q4. Both channels take their driving signal from Q4, but through different value capacitors, which gives them their frequency sensitivity. Each channel has a driver transistor, which feeds a triac, which switches the load.

The board, as supplied, is assembled and tested, but requires a few additional components before you can use it: a line cord, plug, sockets, and a plastic box. I highly recommend a fuse, switch, pilot light, and knobs for the pots. [The unit has a switch on one of the pots, but using that makes you lose your sensitivity adjustment. Placing a toggle switch in the circuit allows you to turn the unit on and off without disturbing your settings.]

Here is the hookup diagram, as supplied by Electronic Goldmine:

Obtained from Omarshauntech.com

G3319

CAUTION: MAKE SURE THAT THE COLOR ORGAN BOARD IS MOUNTED IN AN INSULATED CASE AND MAKE SURE THAT THE WIRES TO THE LAMPS ARE INSULATED. DANGER OF ELECTRICAL SHOCK IF YOU COME IN CONTACT WITH 120VAC LINE VOLTAGE ON CIRCUIT BOARD OR LAMPS!

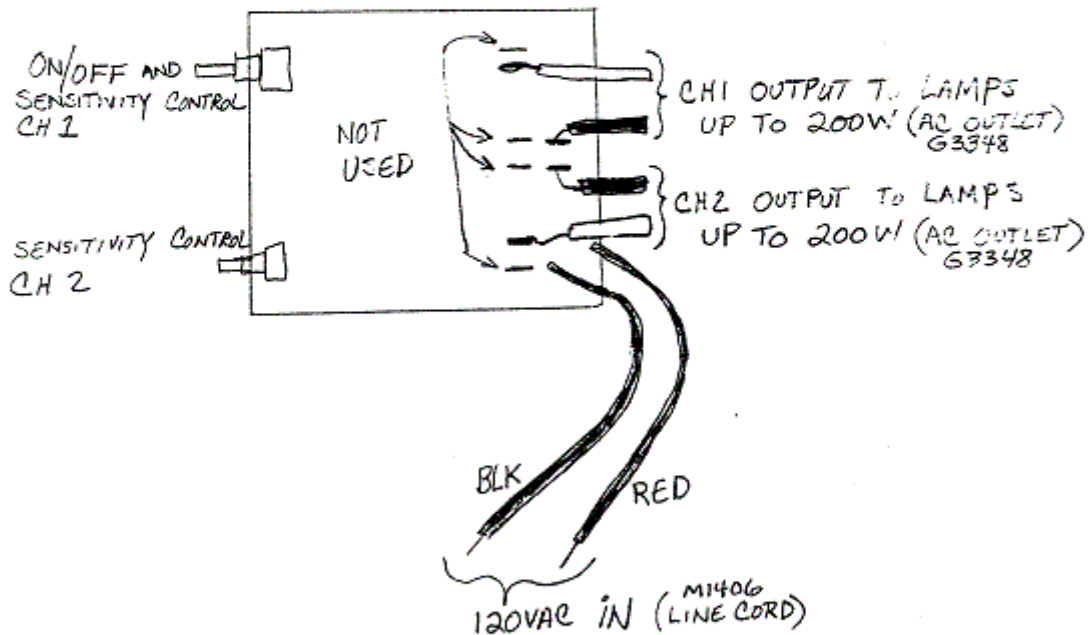

① IT'S A GOOD IDEA TO ADD A 5AMP FUSE IN SERIES WITH THE POWER INPUT RED LEAD

② DO NOT USE ANY OTHER TYPE OF LAMPS EXCEPT STANDARD RESISTIVE TYPE INCANDESCENT. TRANSFORMER TYPE LAMPS INCLUDING FLUORESCENT TYPES WILL NOT WORK AND MAY DAMAGE THE UNIT!

We added some additional components, and wired it for three-prong power connectors:

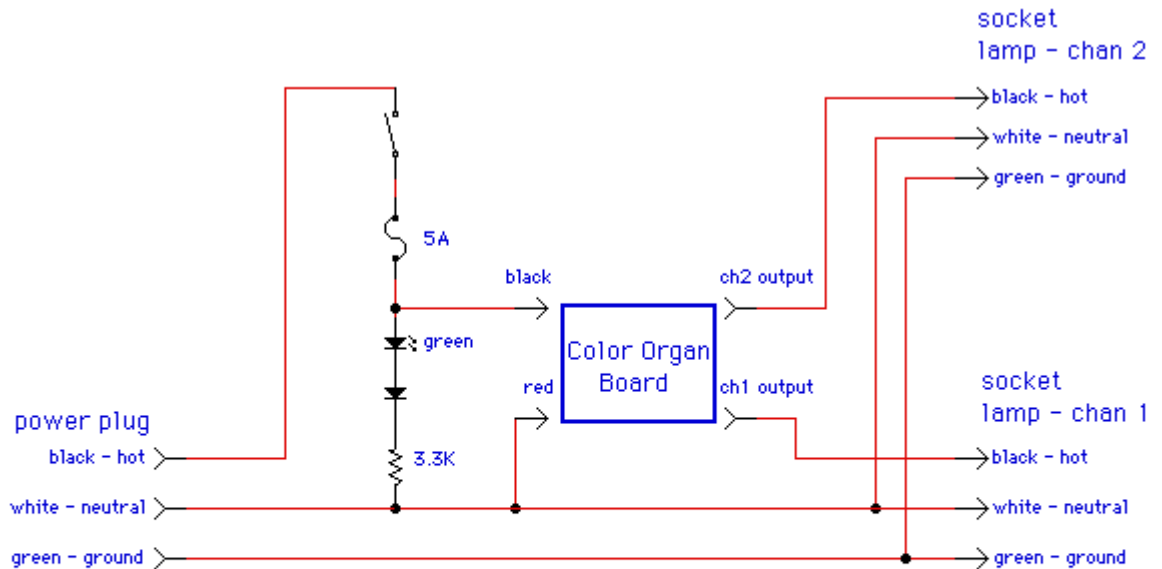

Notes:

- o Project must be assembled in a plastic case.
- o Use only incandescent lamps.

Using the 2-channel color organ board, from Electronic Goldmine

There are a few flaws to the Electronic Goldmine color organ. The first is the triacs that drive the output load are decidedly wimpy — I want more than 200 watts per channel. That much might be enough to make a couple of strings of Christmas lights dance to "Jingle Bells". But lightning requires brief but intense bursts of light, which translates into large current peaks. I know this from experience. Luckily, the triacs are easily replaced with ones that can handle more power.

- I used [Radio Shack](#) part# 276-1000 (6 Amp, 400 Volt), that can be used for a little over 600 watts.
- Wolfstone reader Brittainkr wrote to me in November 2005, saying that he used NTE 5608 Triac (8 Amp, 400 V). These parts have same pin out as the ones that came on the board. "The upgrade worked great with 2-250w photo floods! Wow what a difference the photo floods made." Thank you for the feedback!

You can replace the triacs either before you burn them out or after. ☺

The second flaw is that the sound input to the unit is via a microphone. The assumption is that one will place the unit on or near one of the speakers of the stereo, and rock on. If you happen to clap along with the music, the unit will hear it, translate the sounds into light, and you can groove on that, too. This is something of a handicap in the lightning situation, where we don't want stray noises causing "lightning strokes".

I worked around this by placing a small speaker in the plastic box that houses the color organ. An L-pad in the box allows adjustment of the overall sound level coming out of the speaker, and

going into the microphone. The plastic box tends to protect the color organ from hearing undesired sounds - mostly.

The easy availability of environmental CDs for sound, prebuilt color organs for control, and inexpensive lamp fixtures make this setup the cheapest way to go for reasonable lightning effects.

As a class, irrespective of manufacturer, color organs tend to have additional problems:

1. The sensitivity controls are finicky and will require careful adjustment so that you get plenty of bright light when the lightning strikes, but little flickering or glow when there should be no lightning.
2. When incandescent lamps are operating at less than full power, they look distinctly yellow. Since some thunder strikes will be loud and others less so, some of your lightning will run the lamps low and look yellow. Most people prefer their lightning white or blue-white. This can be remedied by using a bluish photoflood lamp, or perhaps a colored gel over the lamp fixture.
3. The filament on an incandescent lamp does not instantly change from off to fully bright, nor can it turn off again instantly. It takes it a fraction of a second, which spreads out the flash, making it seem a bit longer than it should be. In a theatrical situation, you could justify the cost of special bulbs with "fast filaments", which help a bit.
4. Cheap color organs are unable to handle the power requirements for really bright lights. If you start with a cheap color organ, you must either limit yourself to small lamps, or upgrade the triacs that drive the lamps so that they can handle a greater load.

Other considerations:

- You might be tempted to use quartz-halogen lamps for your lightning. They are plenty bright, and produce nice white light. Quartz-halogen lamps are probably not a good idea for several reasons. Halogen lamps exhibit a slightly reduced lifetime if not run at full brightness all the time. Halogens are usually high wattage and will strain or destroy inexpensive color organ units. Some quartz-halogen fixtures use a low-voltage lamp, with a transformer to power them from the mains. The inductive load of such units are particularly likely to ruin your color organ. Lastly, halogen lamps tend to have massive filaments, which take significant time to heat up to full output and color. This makes ordinary halogen lamps poor choices for brief flashes.

In all, color organs driving incandescent lamps can provide an excellent source of canned lightning — if you are not too picky.

Some Helpful Technology - The Strobe Light

The problem with much homegrown lightning is inherent in the incandescent lamp that is used to generate the actual light. It relies on using electricity to heat up a metal wire (filament) until it glows white-hot (black-body radiation). This heating and cooling process is not instantaneous, due to the heat capacity of the filament, so it inherently slows down the light flashes.

But there is an alternative: the strobe light. If you would like background information on what a strobe is, how it works, and where to get them, please visit our strobe page.

The light from a strobe tends to be a very nice white or blue-white color. The combination of color, intensity, and brevity make xenon strobes look a lot like lightning flashes. In fact, one could argue that they actually *are* miniature lightning flashes, since lightning is itself a rapid gas discharge of energy stored in cloud capacitors! There is a problem, though - a single xenon flash is too brief to convincingly simulate a lightning flash. This is because a lightning bolt is not just one discharge, but hundreds, one right after another.

Method 2 - Color Organ Driving Strobe

Some folks start out with a color organ, but don't plug an incandescent lamp into it. Instead they plug in a strobe light, adjusted for maximum flash rate. When the thunder strikes, it provides power to the strobe unit, which flashes as fast as it can, providing the multiple flashes of a lightning bolt.

The cost of even an inexpensive AC-operated strobe unit substantially increases the price tag of this solution. Expect to pay at least \$20 for a small strobe. You can still find strobes at Radio Shack these days, if you can resist the merchant's attempts to sell you a cellular telephone.

A common failing of inexpensive strobe units is that their repetitive flash rate is not terribly fast. Even when you crank 'em. They do, however, give you a nice blue-white flash of short duration similar to a real lightning strike.

Another problem is that you are likely to get all of your flashes at a single repetition rate, as long as there is loud noise. This looks distressingly artificial. [I say likely, because it depends on the technology used to implement the trigger oscillator in the strobe light.] Ideally, the lightning flashes would vary in intensity, duration, and repetition rate.

Note:

- Running a strobe off of a color organ is not particularly hard on the strobe. Strobes are already pretty strange gadgets and their working parts are already rather stressed; using a color organ to turn them on and off usually doesn't hurt them.
- Strobes draw a lot of power. If you try running a color organ off of one, the color organ must be beefy.
- Not all color organs will work with all strobes. It depends on the type of switch used by the color organ to control the load, and the way in which the strobe power supply is designed.
- Color organs that use SCRs to switch the output power instead of TRIACs produce half-wave power. You will probably have a lot of problem with this configuration. Try to get a color organ that uses a TRIAC.
- If your strobe does not work with your color organ, try rotating the strobe plug in the color organ socket.

Which Looks Better?

There has been some debate between the nice folks on halloween-1 concerning the esthetics of incandescent versus strobe as light sources controlled by a color organ. Suffice it to say that this is a matter of taste. Some folks prefer the lingering flash afforded by the filament of an incandescent lamp. Others prefer the color and intensity of a xenon strobe burst.

In my own opinion, neither approach is ideal. A single pulse from a strobe is too short, and the one from an incandescent is too long. I would suggest using some of both. If you use a two-channel color organ, you can plug an incandescent lamp into one channel and a strobe into the other. This gives you both short and long flashes, as well as flashes from multiple locations at different times. This adds an illusion of motion, or gives a feeling that lightning is coming in from all sides.

I actually use a hybrid approach: a two-channel color organ driving a pair of 500-Watt blue photoflood lamps in aluminum clamp-on light fixtures; plus a special purpose-built xenon flash unit, which is described next.

Method 3 - Dedicated Xenon Unit

Just plugging a xenon strobe into a color organ is a quick hack, but I don't believe that the effect is very realistic: as long as the sound is loud, the flashes come at a fixed rate. I would prefer an approach that does not have such a timing artifact that makes it look artificial. Luckily, there is such a device.

In order to make use of this section, you need a good understanding of how a strobe light works, and why. If you haven't already done so, please visit our strobe page.

WARNING - Xenon strobe circuits can be very dangerous to work with, because they store up a large amount of energy in a capacitor and can release it all at once. If you purchase any kind of flash unit prebuilt, don't open the case - there are potentially lethal voltages inside. The unit described in this section is not available commercially, so if you want one, you must build it yourself. If you are not qualified to do this, find somebody who *is* qualified and get them to build the unit. Even unplugged and turned off, these units can be lethal! The xenon tube itself should have a transparent cover, in the event of catastrophic failure.

A reader of Nuts&Volts magazine wrote in, asking for a circuit that could be used to flash a xenon lamp in time with a lightning sound track. In response, the June 1995 edition published just such a circuit on page 77. It was sent in by reader Tim Naami, who credited it as a "project of the month" published by GC Electronics. There are several mistakes and omissions from the circuit diagram, which I discovered when I attempted to build the unit. A corrected schematic follows.

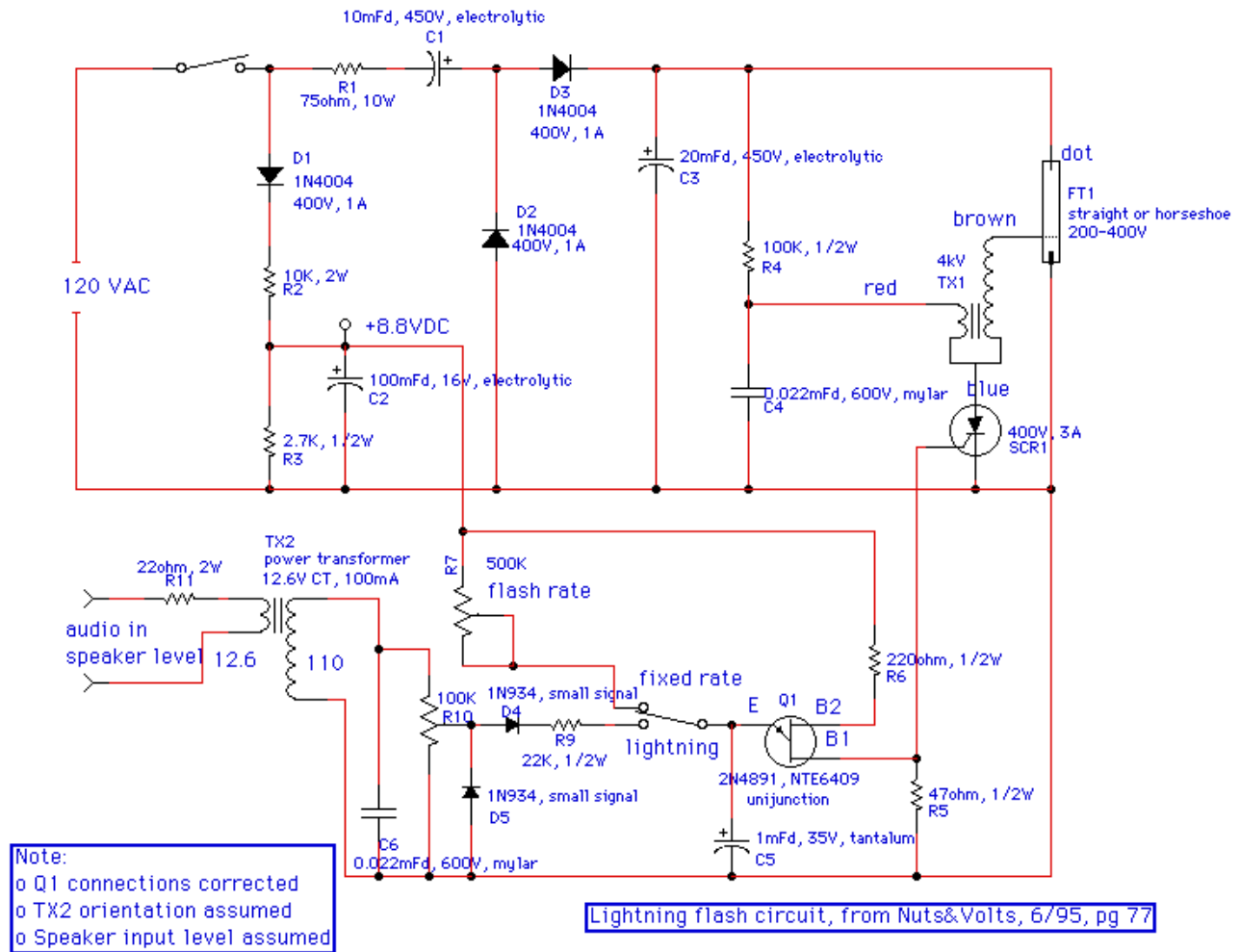

The circuit operates as follows: D1 and associated circuitry form a low voltage DC power supply for the intelligent part. C1, C3, D2, and D3 for a voltage doubler, providing roughly 330 VDC to feed the flash tube. Meanwhile, Q1 acts as a voltage-controlled oscillator (VCO) that regularly fires the SCR, which discharges C4 through trigger transformer TX1, which fires the flash tube. If all you want is a regularly flashing light, you flip of the switch and can use R7 to feed various different voltages into the oscillator, changing the frequency of flashes. When used for lightning, the speaker-level audio signal is isolated by TX2, and through R9, integrated on C5, driving the oscillator. The louder the sound, the higher the voltage on C5, and the closer together the flashes.

Notice that this unit works somewhat like a color organ, in turning sound into light. One would be tempted to compare this to a strobe plugged into a color organ. There is a significant difference, though: When the color organ combo hears something loud enough, it flashes at the fixed rate. *This* unit flashes faster when the sound gets louder; so at the peak of the thunder noise, the unit is firing flashes rapidly, and during the softer crashes, there are less frequent flashes.

When built this way, the unit functioned, but I found it wanting.

I don't *ever* build a strobe circuit without a bleeder resistor across the energy storage capacitor (C3). 1M, 1/2-W is a reasonable value.

I like to have a fuse in any line-powered project that I make - just in case. I used 1A, slo-blow.

The flash was not very bright. Capacitor C3 could be increased considerably. I got good results adding another 150 uFd in parallel with C3. Make sure that your xenon tube has a high enough rating to take the additional power.

The unit was not very sensitive. To trigger, it required the stereo to be very loud and sensitivity control R10 to be on full. There are other solutions:

1. R9 could be reduced to speed the charging of C5 in the VCO. A value of 5.6K seems to help a lot.
2. R10 could be increased, effectively allowing you to turn the sensitivity further up than the current maximum.
3. The value of R11 could be reduced, allowing more of the speaker energy into the circuit to begin with. I haven't gotten around to trying this yet, but it should work fine.
4. Don't use the unit in parallel with a speaker, but in place of it. This didn't seem to help at all.

With the above factors taken into account, the unit does a good job.

Some Questions, Answers, and Comments

- ***What should I do now?***

Step 1 - Build a color organ from a kit or based on the prebuilt board. Get one that is at least two channels, or use a pair of single-channel units, set to different sensitivity levels. Hook it up to a pair of incandescent lamps. Attach to your stereo, and try it. Most important: do *you* like the results?

Step 2 - Obtain a strobe and plug it in place of one of the lamps. Compare the light you get from each. Most important: do *you* prefer the incandescent or xenon effect?

Step 3 - If you like the xenon, consider the purpose-built lightning unit presented last. If you do not have experience with high-voltage circuits, get an experienced friend to build it for you.

- ***This is sounding too complicated for me!***

Color organs are excellent starter projects for those new to electronics. Just pick a KIT and go with it. You will produce a reasonable unit, save money, learn some electronics, and build confidence in your abilities.

I do not recommend building a color organ from scratch because: (1) hunting up the parts can be a pain [I am still looking for a DI-733 transformer for a color organ I started building in 1971!] (2) buying the bits and pieces will likely cost more than getting them all in a kit (3) the kit will come with a printed-circuit board, which makes assembly much easier (4) most kits include some instructional "this is how it works" material (5) kit are often designed to be simple and foolproof (6) if the unit doesn't work and you haven't abused it, you can get it serviced.

- ***Should thunder follow lightning?***

Everybody knows that there is a delay between a flash of lightning and the sound of thunder that it produces. The physics is simple: light travels faster than sound; the further away the lightning strike is, the greater the delay between the light and the sound. But what ramifications does this have for the haunter?

In an effort to faithfully mimic nature, we tested this by preparing a special stereo CD. On this recording, one track was intended for sound and contained the lightning storm sounds. The other track consisted of identical sounds, slightly delayed. We fed the original sound into the speakers and the delayed sounds into the lightning circuits.

We actually found the results disappointing. If the delay is long, one loses the psychological connection between the light and sound; you are simulating a lightning storm three counties away. When the delay is short, it isn't that much more effective, but still costs the stereo effect of the sound. We won't bother with that again.

- ***Should the thunder be in stereo?***

I believe so. It provides an audio sense of surroundings, depth, and motion - all of which enhance the realism.

- ***How many lamps do I need?***

In the same way that stereo sound provides an audio sense of realism, you want multiple lamps to provide a visual sense of surroundings, depth, and motion. And it won't do to have several lamps all driven from the same color organ channel. You want lights flashing differently in several different directions at once.

This translates into at least a two-channel color organ.

- ***Where should I place the speakers?***

Think stereo, so the speakers should go on either side of the listener. Since you don't want just a small zone of stereo effect, they should go out to the side as far as possible.

- ***Do I need special audio equipment?***

Not particularly. You will want it loud, and a thunder storm has quiet places and sudden loud places, so make sure your speakers and amplifier can handle the peaks.

- ***Does it matter where I put the lightning lamps?***

Putting any lightning in your haunted graveyard is good. Putting it in the right place is better.

The first year we used lightning, we attached the lamps to the eaves of the house, as close as possible towards the street. This cast the lightning down the rows of the gravestones, which were set up parallel to the street, so that passers-by could easily read them.

The second year, we put the lamps in a small tree near the street. This cast lightning flashes on the face of the tombstones, which made it spookier.

- ***Where can I get photoflood lamps?***

As I have already mentioned, photoflood lamps are made to more closely resemble natural sunlight, and have a slight blue tinge to their light. I prefer them to standard incandescent lamps. But where do you get them?

One source is 1000bulbs.com, catalog code STAG/BBA, \$2.67 each [October 2004].

They describe it as follows: BBA, Audio Visual / Photographic, E26 Base, Volts 120, 250 Watts, Length 4.94 in., Diameter 2.68 in., Filament C-9, Base E26, Special Desc: Inside Frosted, Lumens 8500, Color Temperature 3400, Average Life 3 hrs., Type Use Photoflood.

The "Average Life 3 hrs." is not a typographical error. Lights of this type tend to have short lives. But that's only when run on full power, 100% duty cycle. When attached to a color organ, the lamps will spend most of the time off, with occasional flashes when the thunder strikes. I have been using one set for 6 years.

- ***What could make it more realistic?***

You could simulate rain with occasional sprays of actual water. You could add the sounds of blowing rain and wind. You could provide actual blowing wind, complete with dancing leaves.

- ***What if I can't find the color organ kit that you suggest?***

Numerous sources for color organs are listed on our color organ page.

- ***Where can I find a strobe kit?***

Numerous sources for strobes are listed on our strobe page.

- ***What should I look for in a strobe?***

Rapid flash rate; high power; AC operation. Remote trigger input might be nice for the future.

- ***What should I look for in a color organ?***

Appropriate audio input (microphone, speaker-level, or line level); 2 or more channels; TRIAC output (not SCR); 200+ watts per channel (500 is better). I prefer a unit wired to the sound source, instead of using a microphone.

- ***You don't understand! I'm too big a clutz to do this!***

Oh.

Then you better run, not walk, to our section on commercial lightning boxes.

- ***Any final words?***

There are as many different ways to simulate thunder and lightning as there are hauntings. There is really no "best" method, merely some that fit a certain set of requirements better than other methods.

Let your imagination be your guide!

Obtained from
Omarshantedtrail.com