

MONSTER IN A BOX

<http://www.cindybob.com/halloween/mib/>

Introduction



When looking for ideas for our 2005 haunt I came across a number of versions of a Monster In A Box (MIB) prop and I decided that I needed to build one of my own. I'm very happy with the way it turned out and thought I would show it off, and maybe help others build there own, with this guide to our build process.

About the only thing that sets ours apart from the majority of other motorized MIBs out there is that instead of using a rod from the cam follower to the lid we mounted the follower directly to the lid. Also our MIB is microprocessor controlled by a Prop-1 Control Board from EFX-TEK.

For tools you will need a jig saw (or band saw), circular saw, drill, screw drivers and wrenches, etc.

No complete parts list for our MIB exists but reading through this guide should give you a good idea of the components we used. In very general terms you will need wood, a Prop-1 control board, a Cowlacious audio board, relays, a power supply, amplified speakers, a windshield wiper motor, light sockets, power receptacle, wire, nuts, bolts, washers, wood screws and other hardware.

It's hard to place a definitive price on this prop since it was made from a combination of components we already had, some salvaged parts and some purchased parts. It is however

not a particularly cheap prop to build but also not an overaly expensive one . Have a look at the table below (and see the Links section for other sources) for a very rough estimate of the component costs. Basically you should look to budget about \$200 to build your MIB.

Table 1. Parts Estimate

Prop-1 Control Board	\$35.00
Cowlacious Chipcorder Player Board	\$17.95
PIR Sensor	\$7.95
Other Electronic Parts (relays, pots, switches, leds, etc)	~\$20.00
Powered Computer Speakers	\$9.95
Windshield Wiper Motor	\$15.95
Power Supply	\$10.00
Other Electrical Parts (wire, receptacles, light sockets, etc)	~\$25.00
Wood and Hardware	~\$25 - \$100
Total	~141.80 - \$216.80

If you are inspired to create your own Monster In A Box you might at least get a few ideas and tips by reading through the material presented here and the other versions of MIB available. And please take some pictures and send us the link so we can add it to our Links section and you can show off your work.

The documentation of the build process for our Monster In A Box came well after the prop was actually built so there are likely areas not documented or unclear. If you have a questions, or notice any errors in the documentation presented, feel free to send us an email us at halloween@cindybob.com. Since we are always tinkering, any additions and changes we make will be first documented in the Modifications section rather than rewriting the guide each time.

Addition: Crate shaker added March 2006. See the modifications page for details.

Addition: Monster added April 2006. See the modifications page for details.

Bellow are some photos and videos of our Monster In A Box. These and most of the images in this guide can be enlarged by clicking on the image.

Please take a minute to [leave a comment or a suggestion or criticism](#) and read what others have to say.

Note: This guide was designed to display properly in Internet Explorer. No effort has been made to make it cross browser friendly. Sorry.

⚠Warning: This prop requires 120V AC line voltage.Line volatage can kill! Please be careful. We are just plain not responsible for anything!



Crate Construction

How you build the crate is really up to you as almost any configuration can be adapted for use.

Our's is 40 inches wide by 19 inches deep and 28 inches high. It was made quite simply by using salvaged pallets (the flat type, not the block type - I believe they are referred to as skids - see Figure 1 for an example). Four pallets were cut to size for the front, back, top and bottom. The excess wood was used to create panels for the end sides. Two 2x4 rectangles were made to form a frame on either end. The bottom, front, back and sides were attached to these frames using wood screws. The top was added using four medium duty steel tee hinges similar to these from [Home Depot](#).

Figure 1. Skid



For effect we added some stenciling to the crate. The stencils were made on the computer using a large stencil font, printed on stiff paper and cut out using an Exacto knife. We also used some light chain over the top (with enough slack for the lid opening) through four small u-bolts down to a large eye-bolt and lock.

The pictures below should give you a good idea of our crate construction.

No matter how you are going to build your crate there are a few things to keep in mind. First, the crate really should be large enough to hold something ferocious. A small 1'x1' crate bumping around and growling would be more funny than scary. Second, the crate will take a good beating so it needs to be made strong. Use heavy duty wood screws rather than nails and use lots of them. Make sure that all your bolts are tightly fastened with lock washers. The lid may be the trickier part to get right. It needs to be extra strong but also as light as possible. This is why we used four medium duty hinges rather than two heavy duty hinges. If you are going to use chain you will need to use light chain or even plastic chain (although the plastic chain does not really add the rattle that makes the chain a good effect). Heavy chain will add a lot of weight to the top.





Omar

Mechanical System

Figure 1. Motor



Figure 2. Cam



Figure 3. Cam Follower

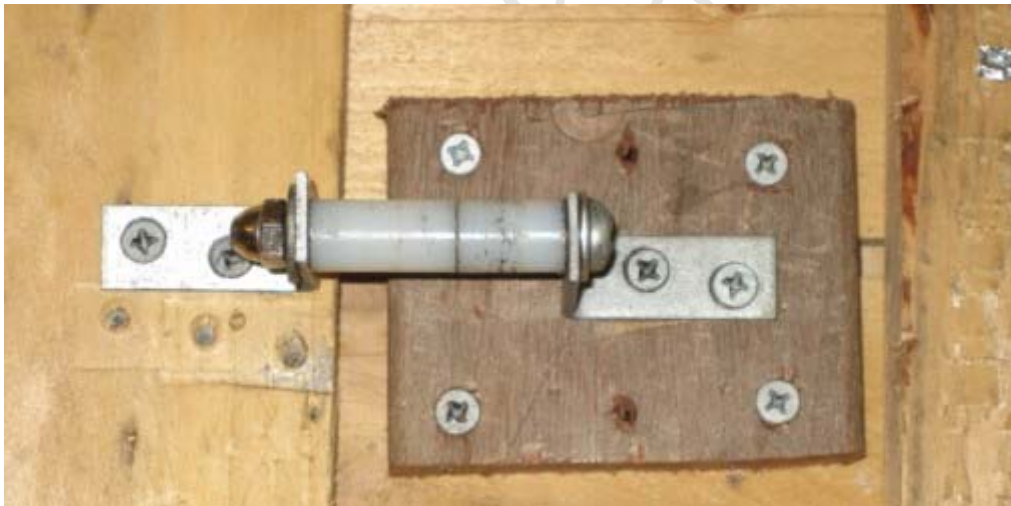

The mechanical setup for our MIB is rather simple. It consists of a [windshiled wiper motor](#) (Figure 1), [a cam](#) (Figure 2) and a [cam follower](#) (Figure 3). What makes our setup different than most other examples of motorized MIBs is that instead of using a rod from the cam follower to the lid we mounted the follower directly to the lid.

Figure 4. Motor Mount



Figure 5. Motor Mount



The motor is a salvaged 12v DC windshield wiper motor that is mounted to the crate using 3 pieces of 3/4 x 1/8 flat bar. The bar is fastened to the motor using stove bolts, washers, lock washers and nuts and fastened to the 2x4 frame of the crate using long wood screws (Figures 4 & 5). The mounting method you use will depend on the motor and the crate construction so there is little use providing much more detail here. However it is mounted, **it needs to be solid**. Online sources for windshield wiper motors can be found in the Links section. The motion of the lid can be exaggerated by mounting the motor (and cam) towards the back of the crate but the motor will need to work harder. Similarly, if you find that your motor doesn't have quite enough power to lift the lid, mounting the motor closer to the front will lessen the work of the motor and decrease the motion of the lid. We opted for an almsot center position.

Figure 6. Cam Follower



Figure 7. Cam Follower

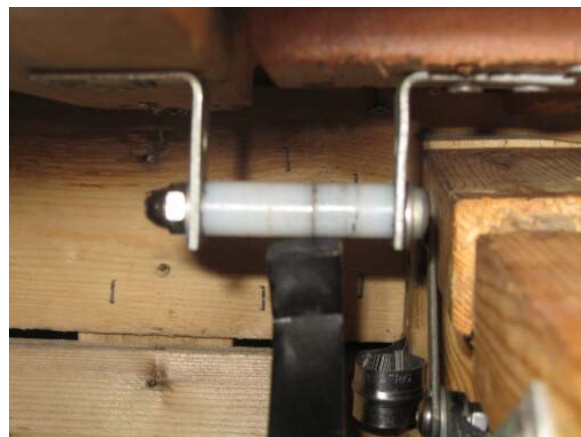
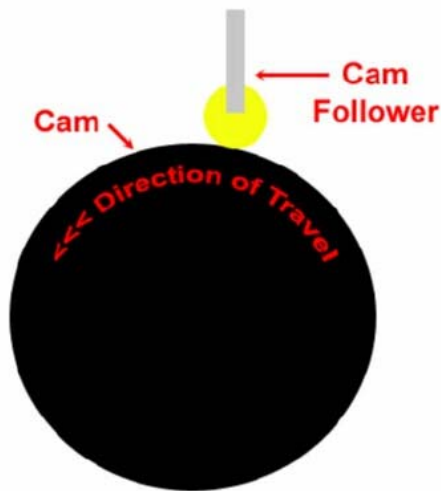

Figure 8. Cam Follower



The cam follower was made using two 1 1/2" angle brackets, nylon spacers, a 2 1/2" bolt, 2 washers and an acorn nut to fasten it together but still allow it to turn freely. The follower was firmly attached to the lid using wood screws (Figures 3 & 6). It should be attached so that the cam hits as close to the middle of the nylon spacer as possible (Figure 7). Through experimentation we found that the cam works best if the follower is mounted slightly off center away from the direction of travel (Figure 8).

The cam design and attachment to motor turned out to be the most problematic part of the project. In 2005 we used a basic spiral type cam made of hard plastic. We first tried just bolting it to the motor shaft using a 5/16" bolt but this did not allow enough clearance between the motor housing and the cam. Next we tried bolting a 5/16 round tee bolt to the cam and then simply screwing this on to the shaft. This system worked reasonably well but over the course of use it failed twice. Once the small bolts used to connect the tee bolt to the cam ripped right through the plastic material of the cam and once the tee bolt threads completely stripped and turned freely on the motor shaft. Nor were we all that happy with the pattern of one lift per revolution created by the single lobed spiral cam.

(Note: Our motor has a 5/16" threaded shaft, the motor you use might be a different size so you will need to adjust any dimensions or parts mentioned to accommodate this.)

Figure 9. Mounting Parts



Figure 10. Arm



Figure 11. Coupler



Figure 12. Spacer



Figure 13. Bolt

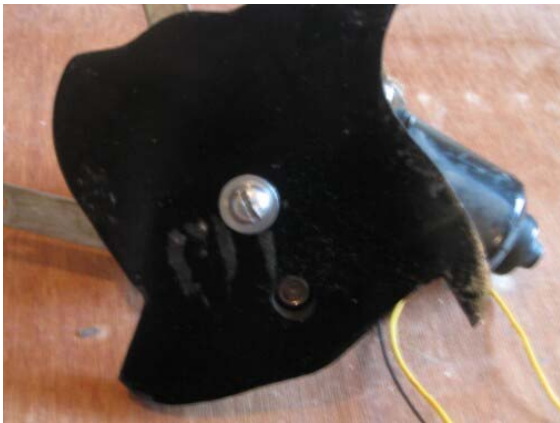

Figure 14. Cam



For 2006 we decided to see if we could develop a more reliable method for attaching the cam to the shaft and a more active cam design (as well as documenting the build method). We concentrated first on attaching the cam and after a fair amount of trial and error what we came up with involves using the arm and ball joint that comes with the motor, a 5/16-18 shaft coupler, a spacer, and 5/16"x1" stove bolt (Figure 9). We drilled two holes in the cam. The first a 1/2" hole in the center of the cam to accommodate the shaft coupler and the second a 5/8" hole, offset from the center of the first hole by 1 5/8", to accommodate the ball joint on the end of the arm (Figure 2). Place the arm firmly on the shaft (Figure 10) and tighten the shaft coupler firmly against the arm (Figure 11). Next place the spacer over the shaft coupler (Figure 12). The spacer is there to keep the cam straight up and down when the bolt is tightened. The spacer can be pretty much anything between about 1/4"-3/8" thick. We used an old bearing simply because that was the first suitable thing to come to hand from the bits bin. Next place the cam over the shaft coupler and the ball joint and tighten it down using the 5/16" bolt and a large fender washer and lock washer (Figure 13).

We also did a fair amount of experimentation with different styles and materials for the cam. Our final choice was made from $\frac{3}{4}$ " thick particle board. It started as a $6\frac{1}{2}$ "x $6\frac{1}{2}$ " square. The four corners were then rounded off. By itself this made a fairly good cam but we decided to add various dips and lobes to the cam to make the action more violent and random appearing. This involved careful use of a jig saw, a lot of sanding and a lot of trial and error (if you have access to a band saw you can save yourself a lot of sanding time). Once we were satisfied with the shape of the cam we spent a lot of time sanding the edges to the smoothest finish we could get. This combined with painting the cam with spray lacquer and liberally lubricating the cam and cam follower reduced the friction substantially. Click on Figure 14 to view a short movie of the cam and cam follower in action. The size and shape of our cam and the mounting position of the motor gives the lid a peak movement of 3"

(**Tip:** The completed cam is likely going to be able to operate in one direction only so it will have a front and a back that you will need to note. You will want to attach it to the motor in such a way that the turning of the shaft and the force of it hitting the cam follower tightens, rather than loosens, any bolts used for mounting the cam to the shaft.)

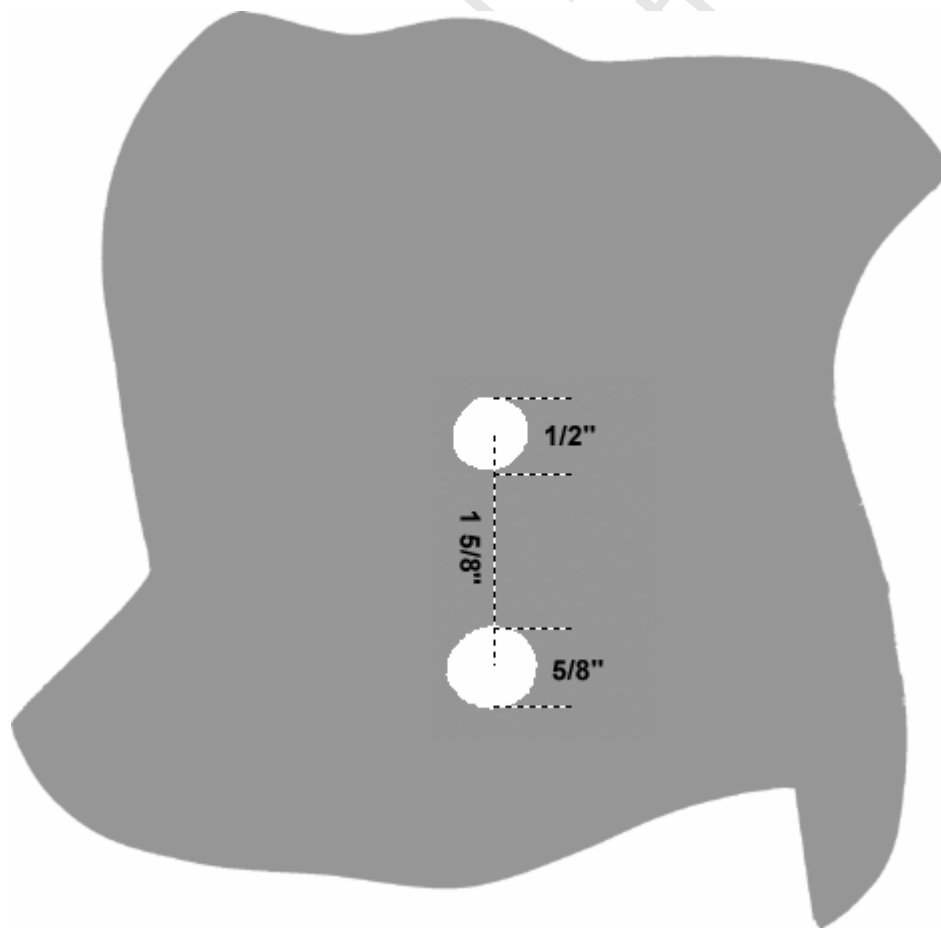

Control System

The control system used by our version of Monster in a Box uses a EFX-TEK Prop-1 microprocessor controlling relays for fog, lights and the motor and providing power to a Cowlacious Chipcorder board for sound. The control system is triggered by a PIR motion detector. See Figure 1 for a schematic of the control system (a [text file description](#) of the connections is also available) and Figures 2 and 3 for pictures of the actual system. To protect the electronics from fog residue the system was mounted in a plastic project box. The external controls and power input was mounted on a control panel fastened to the back of the prop (See Figure 4 and the Electrical System section for more details). Table 1 provides a parts list for the system.

Figure 1. Control Schematic

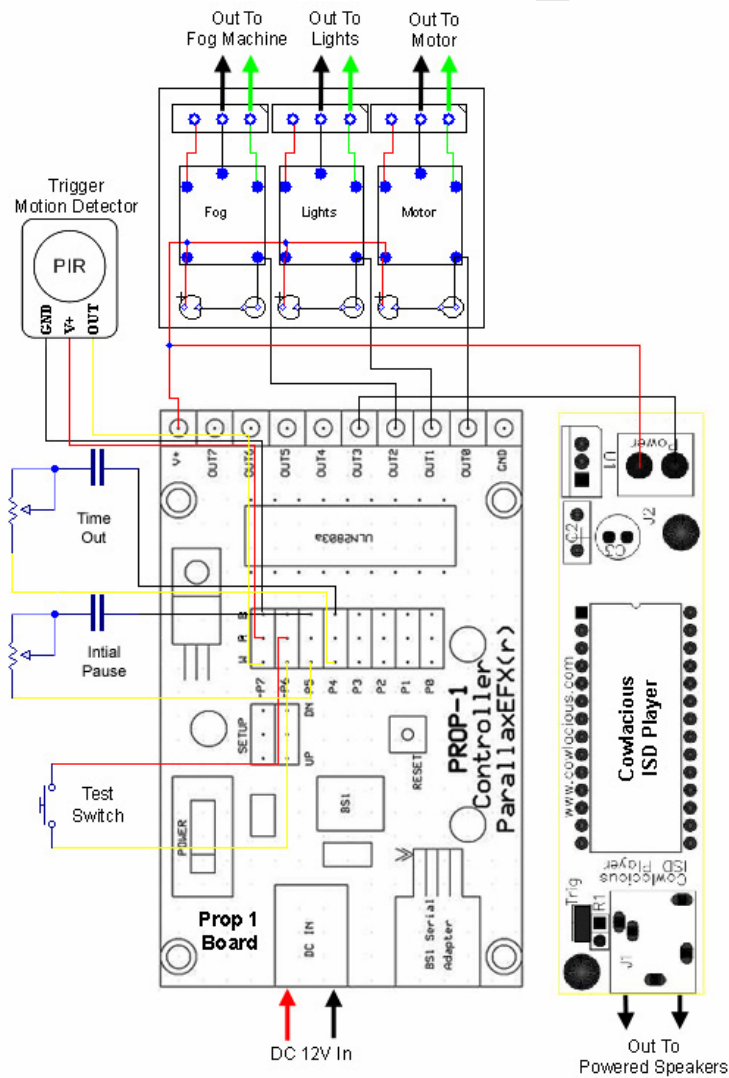

Figure 2. Control Wiring

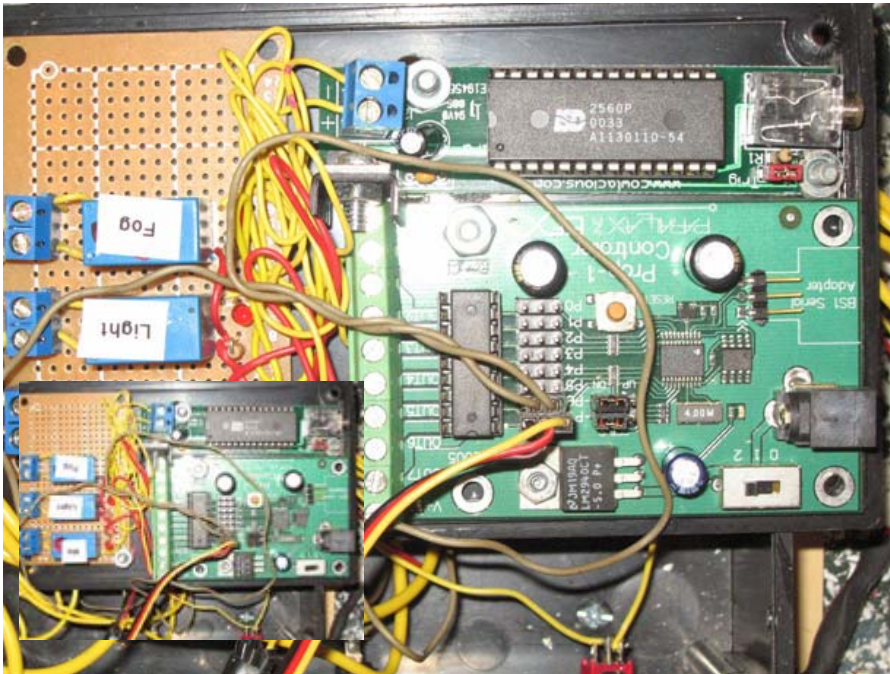
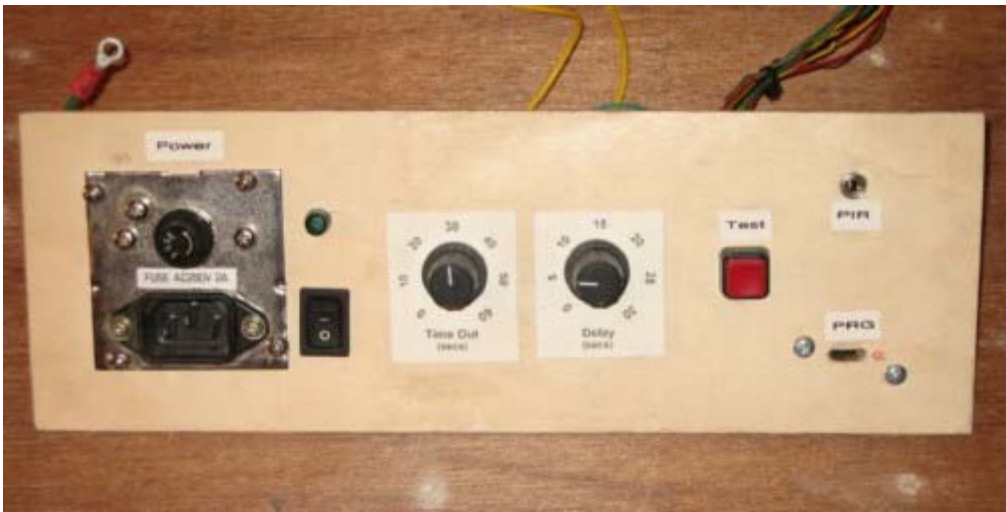

Figure 3. Control Box



Figure 4. Control Panel



Connecting the parts together is fairly straight forward. The motion detector is connected to the 3 pin header of Pin 7 on the Prop-1 board and the test button is connected to the W & R pins of the 3 pin header from Pin 6 (see the schematic Figure 1 for details). Both of these inputs are active-high so the jumpers for both of these pins are set to the DN position (the [Prop-1 documentation](#) provides more information about this).

Two variable resistor / capacitor combination (see Figure 5) are used to set the duration of the initial pause before starting and the lockout time after running before it will retrigger. The program reads the variable resistors using the PBasic POT function when the triggered by the motion detector (read the PBasic help file to learn how to scale the pot to get the proper value). The timeout potentiometer is connected to the W & B header pins of Pin 4 and the initial pause potentiometer is connected to the W & B header pins of Pin 5. (Note: The ULN2803 on the Prop-1 board will interfere with POT readings. To use a pot a simple modification to the chip needs to be made. The documentation for the [EFX Prop-Pot](#) explains the modification.)

The power to the fog machine, lights and motor is switched using mechanical relays. One side of the coil of each of the three relays is connected to the V+ terminal of the Prop-1 board. The other side of the coil controlling the fog machine is connected to the terminal block for Pin 2, the lights relay to Pin 1 and the motor relay to Pin 0. Using the terminal blocks for these connections allows the board to switch the 12V relays directly through the on board Darlington array. A led/resistor combination is connected across each relay to act as an indicator but is not needed for the system to function. .

Figure 5. Variable Timing

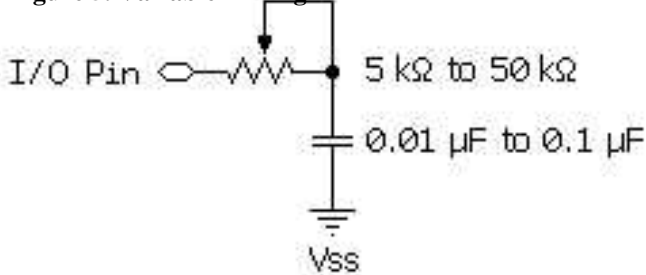

For the sound, the positive side of the power input on the ISD ChipCorder player board is connected to the V+ terminal of the Prop-1 board and the negative side is connected to the Pin 3 terminal. The trigger of the audio board has a

jumper in place to cause the board to begin playing when power is supplied (see the [ChipCorder Player board documentation](#)). This setup proved to be the most reliable method for preventing false triggering of the audio board. A pair of powered computer speakers is connected to the output of the audio board. The monster sound used in our version is available by downloading the [monster1.wav](#) file. You will need a way to record the sound to the ISD chip such as the [Cowlacious Chipcorder Recorder/Player Board](#) which could also be used as the player board.

An alternative to the Cowlacious Chipcorder that has come available since we first made our MIB is the EFX-TEK [AP-8 Audio Player](#) which is a more sophisticated ISD player and recorder with a built in amplifier which may eliminate the need for the powered speakers.

The power for the Prop-1 board, the relays and the audio board is 12v DC taken off the modified computer power supply used to power the wiper motor (see the [Electrical](#) step for more information). Since the Prop-1 board is powering the relays and the audio board directly its power switch must be in position 2. (see the [Prop-1 documentation](#)).

Table 1. Parts List

Part	Supplier
Prop-1 Controller	EFX-TEK
ISD ChipCorder player board	Cowlacious Designs
AC powered speakers	Cowlacious Designs
PIR Sensor Module	EFX-TEK
3 - 12V SPDT Relay	Jameco Electronics
Green (3mm) LED	Jameco Electronics
3 - 390 ohm 1/2W Resistors	Jameco Electronics
3 - 3 pin Terminal Block	Jameco Electronics
2 - 25K Linear Taper Potentiometers	Jameco Electronics
2 - 0.1μF Ceramic Capacitors	Jameco Electronics
Pushbutton Switch	Jameco Electronics
12 Volt 1 Amp Power Supply	EFX-TEK
Proto Board	Radio Shack
Plastic Enclosure	Radio Shack

The heart of the control system is the EFX-TEK Prop-1 control board. Although a simple timer circuit (see the [relay timer](#) circuit) could be adapted for use as a controller, using the microprocessor based Prop-1 gives much more flexibility when it comes to triggering and timing the individual components of the system (i.e. fog, motor, lights and sound) without significantly increasing the overall cost and complexity.

The control program waits for input from either the motion detector or the test button. If it's the test button the program cycles through a series of turning the motor, sound and fog on and off and flashing the lights and then immediately returns to waiting for the next input. If the input is from the motion detector the program first waits for a short duration before beginning the cycle (determined by the setting of the Delay pot) and when the cycle is complete it locks out for a number of seconds (determined by the setting of the Timeout pot) to prevent the prop from being retriggered too often. A copy of this very simple [PBasic program](#) is available.



Electrical System

⚠ Warning: This prop requires 120V AC line voltage. Line voltage can kill! Please be careful.

Figure 1. Electrics

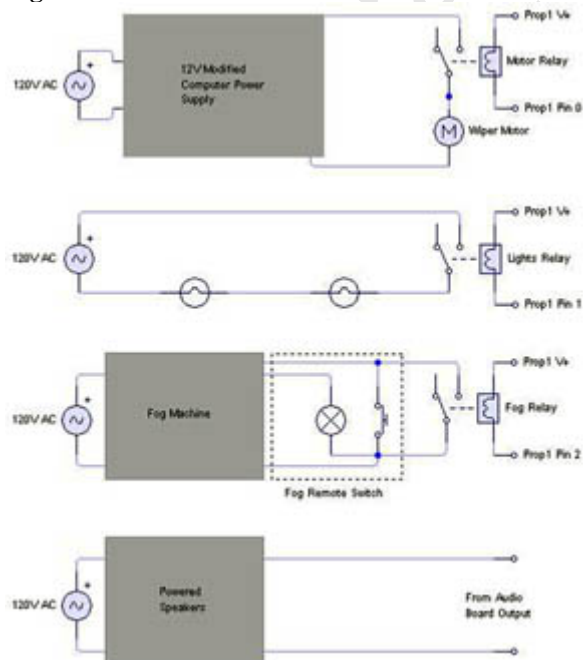

The electrical system for our MIB is composed of four elements. A power supply providing 12V DC to the wiper motor and the control system, two red 120V lights, a fog machine and powered computer speakers to amplify the monster growls. The first three are switched via relays controlled by a Prop-1 control board and the speakers are fed via a Cowlacious audio board also controlled by the Prop-1 (see the Control System section for details).

Figure 2. Power

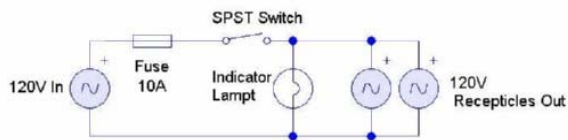

120V AC is needed for the fog machine, two red light bulbs, the powered speakers and the power supply running the motor and electronics. This is provided using a switched and fused IEC male receptacle on the control panel on the back of the crate and a duplex receptacle inside the crate (Figure 2).

Between the fog machine and the wiper motor this prop can draw a lot of current (the fog machine alone draws about 6 amps) so it is important that the electrical system be fused (either separately the way we have done it or by using a fused power bar) and the wiring be of a thick enough gauge to handle the current. You will also want to be aware of the potential high current draw of the prop when adding it to your haunt to prevent overloading the mains circuit.

Figure 3. Power Supply

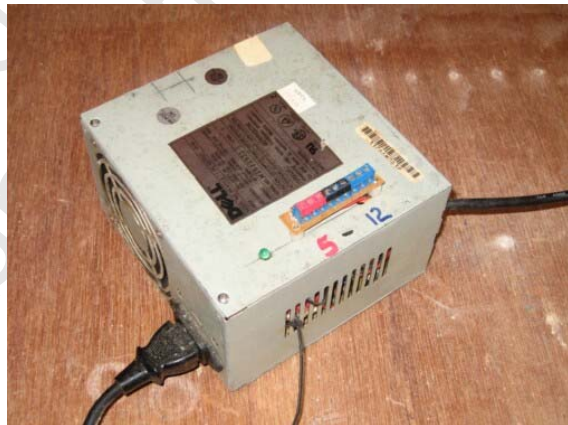
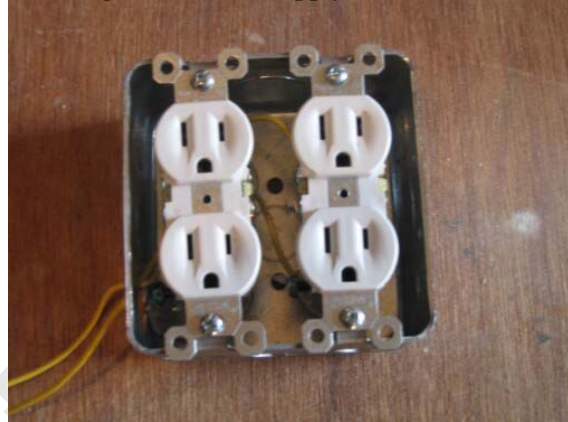

The wiper motor is powered and switched by connecting the ground wire to the negative side of the 12V power supply and the positive wire to the NO contact of the relay connected to Pin 0 of the control system. The positive side of the supply is connected to the Common contact of the same relay. Windshield washer motors can draw a lot of current and need a fairly powerful power supply providing 12V DC (see the information provided by Scary Terry for [using a wiper motor in your Halloween projects](#)). For us the simplest way to provide this was to convert a salvaged computer power supply unit to our needs (Figure 3). Computer power supplies are powerful,

reasonably regulated and easy to come by for little or no money. The modification needed is fairly easy to make and basically just involves adding a small power resistor as a load to keep the supply running. Instructions for converting a PC power supply to a desktop supply are available [here](#) and [here](#). The Links section provides some sources for computer power supplies as well as links to some supplies that could be used without any modification. If you are going to use a salvaged supply you will want to find one that can provide at least 5 amps at 12V. Also you will want a standard ATX power supply. Some of the non-standard supplies (like some Dell models) can be difficult to use.

Figure 4. Fog Modification



The fog machine we used is a 700 watt Gemmy "The Fog Machine" available from Walmart around Halloween for about \$30. The machine is plugged in and the power button is left in the on position. To use the fogger with our control system the push button remote was modified by opening it up, soldering wires to either side of the switch (to allow the relay to short the switch), drilling a small hole in the case for the wires to come through and then closing it back up (Figure 4). Be very careful with this. Once the fog machine is turned on and the remote installed **those wires will be live!** The two wires were then connected to the NO and Common contacts of the relay connected to Pin 2 of the control system.

Figure 5. Speakers



The powered speakers for the sound are a pair of AC powered computer speakers from [Cowlacious Designs](#). They are mounted to the side of the crate, the audio in plug is connected to the audio out jack of the audio player board (see the Control System section), and the speakers are plugged into one of the 120V receptacles and left powered on (Figure 5).

Figure 6. Lights



The flashing lights were made using a pair of [standard base light sockets](#) which are fastened to the side of the crate using angle brackets (Figure 6). The sockets are wired in series (Figure 1) to a lamp cord and plugged into one of the receptacles. The lights are switched through the relay connected to Pin 1 of the control system.

Figure 7. Control Panel



For convenience the power input (socket, fuse, indicator and switch) and all the control system inputs (delay pot, time out pot, test button, PIR jack and programming jack) have been placed on a **control panel** made from a thin sheet of wood and fasten to the inside of the crate using wood screws over a rectangular cutout on the back of the crate (Figure 7).

Figure 8. Elec. & Ctrl. System

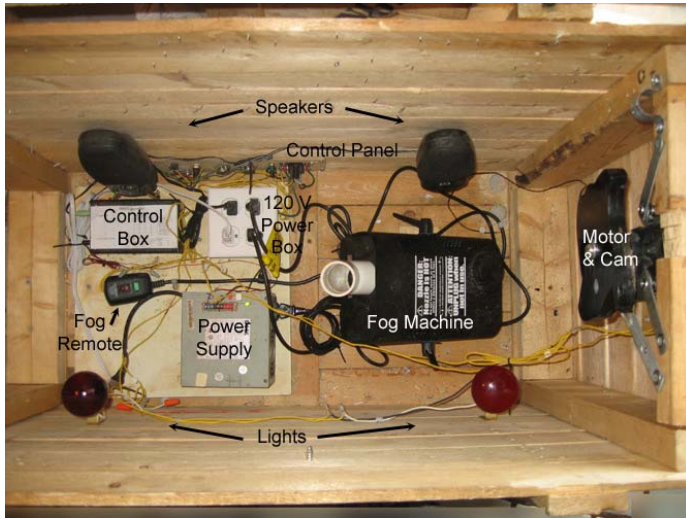

Additions & Modifications

March 2006 - Shake, Rattle and Roll

Figure 1. Before Video

After Video



Figure 2. Push Rod



Figure 3. Hole



Came up with an idea for a simple way to add some shaking to the crate. Decided to give it a try and was reasonably pleased with the results.

Basically it involves a push rod through a hole in the bottom of the crate and the crate sitting on top of a short length of 1" wooden doweling at the fulcrum point. The movement of the lid pushes the rod which tilts the crate up and down. Simple, cheap and effective. Have a look at the before and after videos (Figure 1).

Figure 4. Rod In Place



For the push rod we used a length of 3/4" PVC pipe with caps on the ends (to protect the pipe from the beating). The pipe needs to be as tall as the crate plus the diameter of the dowel used under the crate; in our case 29 inches (Figure 2).

Using a hole saw we drilled an 1 1/2" hole in the bottom of the crate. Through some experimentation we found that best place for the hole was about 2" from the back of the crate (Figure 3). The push rod is placed through the hole and held in place with a 1" pipe strap screwed to the 2x4 frame (Figure 4). The pipe strap is there simply to hold the push rod upright, it should not hold it tight.

A length of 1" wood dowel was cut about 2" shorter than the depth of our crate (Figure 5). The original plan was to attach the dowel

to the bottom of the crate at the mid fulcrum point using counter sunk screws but when testing it we found that when it's loose it also adds a bit of left and right movement to the crate as well as the tilt which we wanted to keep. So, to prevent the crate from moving too far left and right, small wooden rails were screwed to the bottom of the crate about 2

inches on either side of the mid fulcrum point (Figure 6). The dowel sits loosely between these two rails.

That's it. For about an hours worth of work (even with experimentation) and next to no cost we added shake and roll to our rattle.

April 2006 - The Monster

The Monster



Figure 2. Eyes Back



Figure 6. Push Rod



Figure 1. Eyes



Figure 5. Grasping Mechanism



Figure 7. Push Rod

We decided we needed an actual monster in the box. (Click on the photo to the left to see a WMV video of the monster.)

We started simply by adding some glowing eyes but decided to also hand some monster hands that reach out of the crate as it opens. For simplicity we again decided to use the force of the lid movement to power the grasping hands mechanism.

The eyes (Figure 1) were made using some round plastic eyeballs that we found at a dollar store (the same sort of thing could be easily duplicated with ping-pong balls). Each eye contains a red LED and a green LED. The red LED is fitted into a short length of plastic drinking straw that was blacked out to make it opaque. The LED and straw were inserted in the back center of the eyeball and positioned so that the red light only shines through the pupil. It was then glued in place. The green LED was simply glued into a second hole in the back of the eyeball to provide a green glow.

The eyeballs were mounted on a thin piece of board which had holes drilled slightly smaller than the eyeballs using a hole saw. Fake fur was added to the board using hot glue.

The eyes are attached directly to the lid of the crate using small angle brackets (Figure 2) and powered by the same circuit as the motor.

Figure 3. Monster Hand



Figure 4. Monster Hand



For **the hands** we used a pair of cheap rubber costume gloves. Stiff wire was wrapped with duct tape and inserted in each finger to allow for a certain amount of posing. The hands were then ducted taped to a short length of 3/4" pvc pipe. (Figures 3 & 4).

The **grasping mechanism** was done using 3/4" pvc pipe, 3 90 degree elbows, a t-joint, a spring, a dowel and 1" pipe straps. The pictures (Figures 5,6 & 7) give a good idea of how it was put together.

The pipe straps holding the mechanism to the inside front of the crate need to be loose enough to allow free movement of the hands up and down. A bit of lubricant here helps.

Adjust the hands so that they just clear the lip of the crate and reach outward the amount you prefer.

The spring should be just strong enough to bring the hands back upright and to prevent inertia from pushing them all the way down. Fastening the spring in such a way that it slightly pulls the mechanism to the side of the box will counteract the natural tendency of the push rod moving the mechanism away from the side (Figure 7).

The push rod should be just long enough so that when the lid is closed the hands are just inside the box. It is held upright, but loose, with a pipe strap. This pipe strap needs to be large enough to allow for a

Obtained from
Omarshauntedtrail.com