



<http://www.geocities.com/Area51/Nebula/6037/coffin.htm>



By Me (Scott N.)

An article that appeared in Haunted Attraction magazine June 1998

reprinted here with their permission.



Last year for our Halloween party, I wanted a coffin for a room centerpiece. I also wanted it to be realistic and I wanted to be able to use it year after year in a variety of ways. This sent me on a journey of all the stores, web sites, and articles I could find looking for the

right coffin for my needs. All were either cheap cardboard, too small, or too expensive. After a lot of thought I decided to build my own. It cost me about \$300.00 and here's how I did it;

You will need,

Ponderosa Pine boards-two 1"x4"x8' , two 1"x6"x8' , one 1"x8"x8'

Cheap pine boards-four 1"x12"x8' (some knot holes are okay)

ACX Plywood-one 4'x8'x1/4"

Medium Density Fiberboard (MDF) sheet-one 4'x8'x3/4

Crown molding (Homebase #PPR609) one 12' length

Casing molding (Homebase #PFJ428) one 10' and one 7' or equivalent

3/4" pine duck molding (custom molding shop)

tools;

Table saw, miter saw, circular saw, drill & bits, bar clamps, nail set, hammer, router & bits, stapler, tape measure, hot glue gun.

Misc.

2" dry-wall screws, ½" wood screws (silver), 1" finish nails (not silver), wood glue, black upholstery tacks, 5" and 1" furniture foam, polyester lining material, 220 and 100 grit sand paper, stain or paint, 48" piano hinge (Homebase), six coffin handles (AEON).



The first thing to cut will be the base, the measurements will be 17" at the head, 14" at the foot, 28" across at the widest point. From the top to a parallel line at the mid section (widest point) will be 21" and the mid section to the bottom is 53 ½" (see fig 2). The fiberboard is very strong and you will need a sharp blade to cut it. I found that a circular saw with a rip blade works best. Use a strait edge to guide the saw and cut slowly, you may need to use a rasp to smooth up the edge a bit.



Once you have the base you can start on the sides. They will be a little long and cut to size. The sides will be put together with wood glue and the plywood back will strengthen them and make a deco panel. Let's start with the upper side sections. You'll need to cut two pieces of 1"x4" and two pieces of 1"x6" to 22 ½" long and four pieces of 1"x8" to 3" long, use a miter saw for the best edge. Next, put them together like a frame with the 1x4 on top and the 1x8's in the middle and 1x6 on the bottom and glue and clamp the assembly, (see fig. 1) don't worry about the ends

being even, you'll cut them to size later. Next, are the lower side sections. Cut two 1x4's and two 1x6's to 55" long and four 1x8's to 4 ½" long and assemble them the same as the upper sides. You should have four frame sides and a bottom now. Lets work on the foot and head pieces next.

These two ends are made up of four pieces of a 1x12 board. They are two pieces joined side-by-side with wood glue and clamped. After the glue dries cut both to a total height of 17". The foot piece is cut to 14 ½" long and the head piece is 17 ½" long.

Now for cutting the edges of your pieces. Set your table saw blade to the correct height for cutting ¾" stock and set at a 45 degree angle, since your ripping an edge, you need to use your miter fence. The foot and head pieces should be cut at a 45 degree angle. The edge where the upper and lower side pieces meet should be cut at 15 degree angles, keep this in mind (see fig. 2). Cut ONE end of all your pieces (45

degree ends), trimming off only enough to make a uniform edge. Set your pieces on top of your fiberboard base one-by-one where they will go and be sure to have the 1x4 upright. Measure the length (remember, measure twice, cut once) . After your satisfied with the measurement trim the pieces to length. Now you see why we made all the lengths a little long.



All the pieces should be a uniform height of approximately 17" and fit snug next end to end. Note where each piece sits on the base board and mark it. If you need to shim any of the sides to match height, then now is the time to do it. Next you attach the sides to the bottom.

Pre-drill two holes from under the base up into the upper sides with a 1/8" bit (see fig. 3). And use 2" dry-wall screws and wood glue to secure them. Pre-drill three holes for the lower sides and two for the foot and head ends and secure them the same way. The strongest way to secure the edges together is to glue the joints and reinforce them with thin metal brackets. These can be made from tin that is 2" wide and 14" long (see fig.4). Screw the tin reinforcements in place at the inside of the joint and nail the outside of the joints with finish nails on both sides and set the nails, unless you have a biscuit joiner, then that's the way to go, I don't have one.

To make the plywood backing, measure the inside height of your box. Set the table saw blade to 90 degrees and rip the 1/4" plywood to fit. Cut the plywood to length, it will take four sections, two upper and two lower. Now, lay the casket on its side and put glue on the pine side-frames and laminate the plywood sides to the pine (see fig. 5 & 8). To hold this firmly, screw the plywood to the frame with 1/2" wood screws making sure you don't miss the pine frame.

Now is a good time to sand all the sides and clean up any rough edges that will show in the finished product

You should have the box mostly completed now. The frame of pine you made with the plywood backing, has made a deco panel in the side of the coffin. The molding for the bottom will cover the ugly joint where the fiberboard and pine frame meet, this is a trial

and error fit process. Fit the molding all the way around the base mitering all the ends for a neat appearance. For the inside of the deco panel edges, you will need to miter the duck molding at 45 degree angles making a picture frame (see fig. 6). The molding will also cover any nasty edges you might have (I love molding!) Nail this in place and set the nails.

Okay, on to the lid (fig. 7). First, cut three 1x12 boards to 73" long and approximately 8 3/4" wide each, use the fence on your table saw and set it to trim off 1/4" strips until you get to your desired width, you will use these strips later on the inside of your lid. Glue the boards side-by-side and bar clamp them together alternating the clamps one on bottom, one on top, one on bottom, etc. You will need to trim the lid to a width of 25 3/4" after the glue has dried. After the glue has dried, measure the lid to 12" at the foot, 15" at the head, and 26" at the widest point, mark the outline of the casket shape, cut to size with the circular saw and a straightedge. Now, with whatever router bit you like, I used a 3/4" rounding over bit set deep, router around the outside of the lid.

Next, make a frame out of some scrap about 3" wide and 3/4" thick to follow around the underside edge of the lid (see fig.5). This is to attach the lining and crown molding to. When you've done this, glue the frame to the underside of the lid and let it set. While the lid and frame are setting, you can cut and dry fit the crown molding. As with the bottom molding, this is also trial and error fitting. The crown molding will run around the scrap frame just under the routed lid edge. When the glue from the frame is dry, attach the molding using glue and finish nails. The molding has a lip at the top you can conceal the nail under, but you should still set the nail. At the mitered corners, the best way to glue and clamp them is with a miter clamp, if you don't have that then let the pressure of the butt joint hold it. If the molding you use will be what I used, it will be primed for painting, if you intend to paint your coffin then this is fine but I wanted to stain mine so I had to strip the primer off.

Now for the lining. For the bottom you will need 5" thick foam and for the sides you need 1" thick. Figure out how much of the 5" thick foam you will need, I bought a 96x24" roll from a fabric store here where I live called "\$2.00 fabric store" and it cost about \$40.00. The 1" thick foam comes in 2'x4' sheets and I got five of them at about \$4.00 each. The material is polyester lining, it looks like silk which is perfect. I got black. I also bought some black upholstery tacks from an upholstery warehouse at .99 cents for 24, these look like big thumbtacks but when you set them they look like a tuck-n-roll job.

First, fit the 5" foam in the bottom and don't worry about gaps against the side, the 1" foam will cover. Then fit the 1" foam to the sides using the straight edges for the top. Cut the polyester to fit the bottom by wrapping it around the 5" foam, tuck it in good and that's all you need to do. Cut the material for the sides in two long pieces allowing

extra material for wrapping around the foam and for the head and foot ends (e.g. One side is long for the head end and the other is long for the foot end). Tuck the material around the 1" foam and hot glue to the wood behind the foam and at the foot and head ends. The glue will seep through the material and hold the foam as well. Decide where you want the tacks to go, drive them through the material and foam to the wood underneath. The easiest way I found to do this is push the tack in to the foam then just whack it with the hammer and hope it sets in the wood, if you bend the tack just get a new tack. The lining for the lid is a little trickier.

Lay the lid on the floor, stuff the 1" foam pieces between the 3" frame and hot glue them when you figure out the placement. Now, here's where it's a little tricky, put the polyester material on the lid and set the tacks working from one side to the other. You must do this because if you attach the liner to the lid first or try to set the tacks in pairs, the lining will rip, this stuff doesn't stretch! When you have all the tacks in place, cut the material to shape leaving it a little wide so you can staple around the edge in to the lid frame and then take the 1/4" strips of wood, cut them to fit around the inside edge of the lid and over the staples for a neat appearance, hot glue them in place.

Now the final steps. Sand the whole thing and stain or paint it to the color you like. I did not put a top coat on mine, I wanted an old look. The knot holes in the lid contribute to this effect. After I stained mine, I sanded it lightly and gave the edges a worn look.



The hardware for this thing is a 48" piano hinge for the lid, a chain, and six coffin handles. The hinge is from Homebase and the handles came from a company called AEON in Harbor City Ca., their number is (310) 534-0720. They have different styles to choose from and you must tell them that you need handles for a "toe pincher" coffin. They are very helpful and very affordable, my handles were \$15.00 including S&H, there's a minimum of \$15.00 purchase, if you ask them they will send you a picture of the handles and a price list. I used the #3079 in silver at \$1.91 each and was happy with the way they looked. I attached them with the 1/2" wood screws which are silver and look good with the handles. As far as the hinge, just line up the lid and use the screws provided and secure it, you might need two people, the lid is heavy.

This makes a coffin large enough for a six foot tall person and it is 23" wide at the inside middle.

Obtained from
Omarshantedtrail.com

That's about it, the coffin is heavy so don't plan on lugging this thing by yourself. I have been told by people that it's too realistic looking (just what I wanted!) My crown molding has shrunk a bit but it adds to the old look I wanted, I can't wait till Halloween!

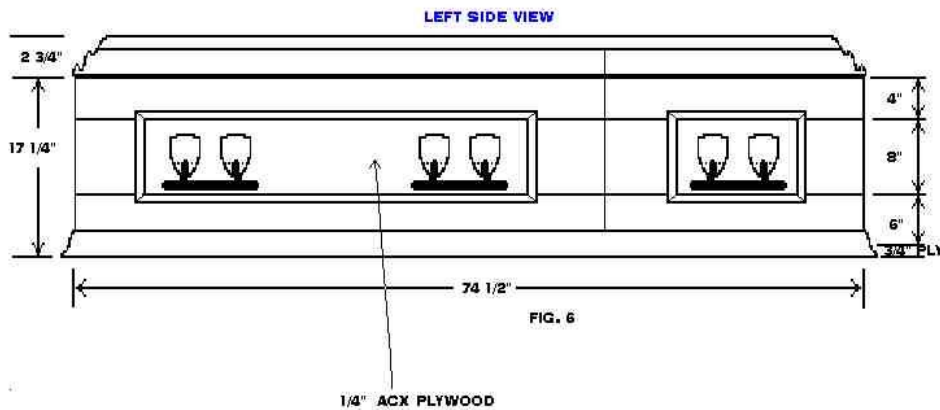
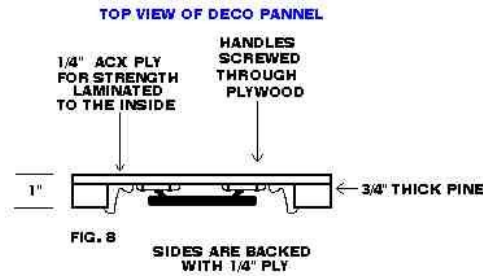

NOTES:

1. JOINTS ARE NAILED AND GLUED
2. BOTTOM EDGE IS SET ON TOP OF 3/4" FIBERBOARD AND SCREWED, GLUED THEN COVER BY BOTTOM MOULDING
3. WIDTH IS 28"
4. HIGHTH IS 19 3/4"
5. CROWN MOLDING #PPR609 TOP EDGE (HOME BASE)
6. CASING #PFJ428 BOTTOM EDGE MOLDING (HOME BASE)
7. SIDE PEICES ARE GLUED AND BAR-CLAMPED, COMPRISED OF 8 PIECES PER SIDE AND THE TOE AND HEAD PIECES ARE TWO 1"X12" LAMINATED PINE BOARDS CUT TO 17" HX 14"W FOOT AND 17"H X 17"W HEAD

NOT TO SCALE

NOT TO SCALE

NOTES:

1. LID BOARDS WILL NEED TO BE CUT STRAIGHT GLUED AND BAR-CLAMPED TOGETHER
2. 3/4" WOOD STRIPS WILL BE USED FOR THE TOP UNDER THE 1"X12" PINE
3. KNOT HOLES ARE OKAY FOR THE TOP
4. BOX IS 1/2" SMALLER ALL THE WAY AROUND

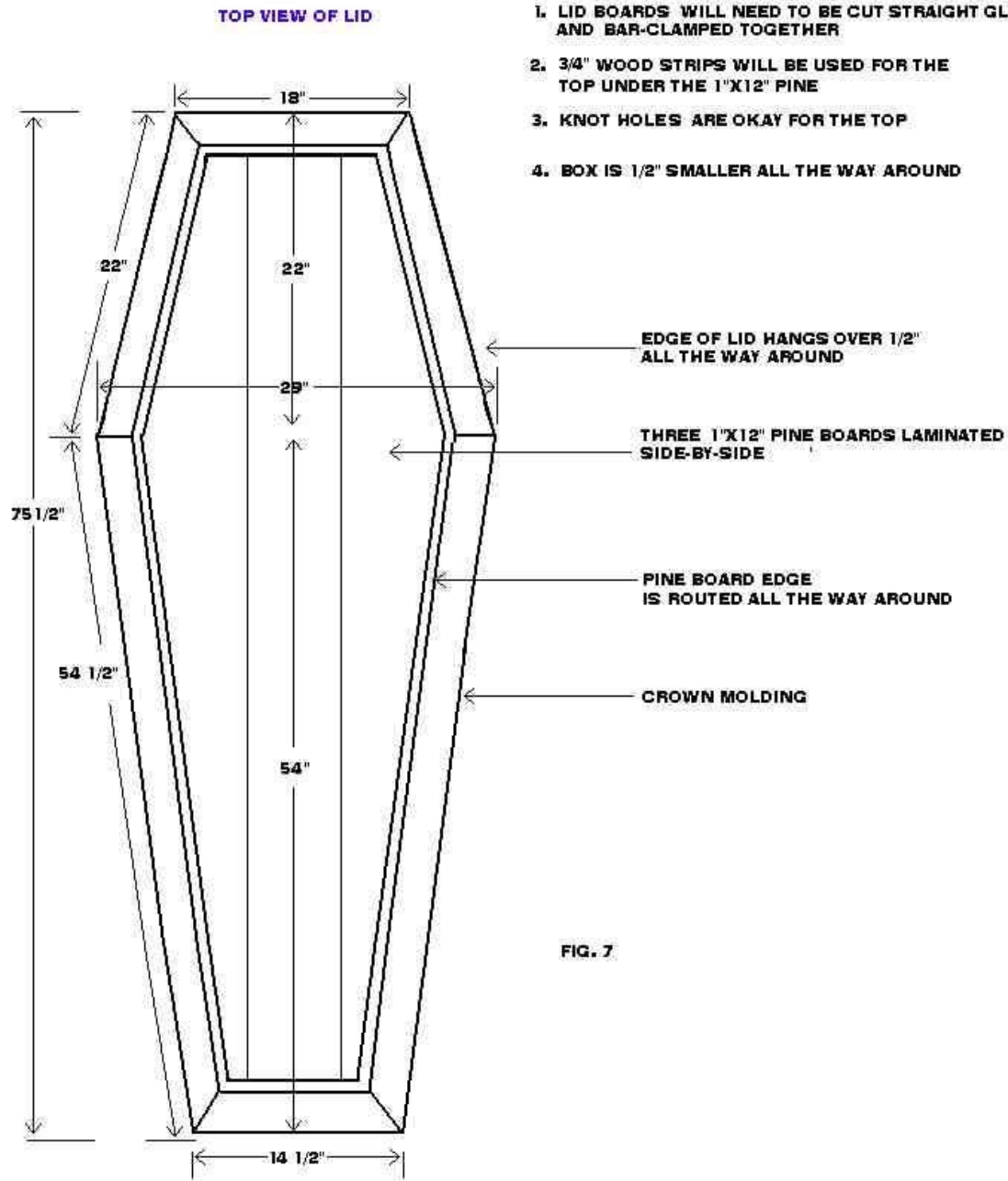

FIG. 7

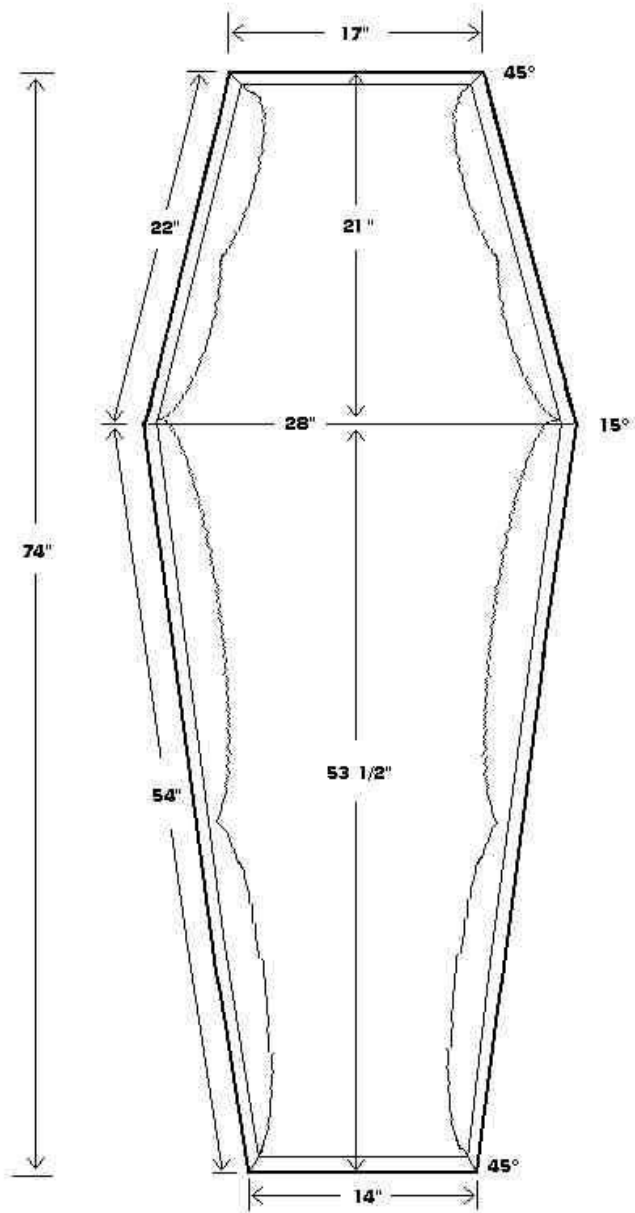

FIG. 2

NOTES:

1. BOX MEASUREMENTS DIFFER FROM LID MEASUREMENTS
2. WOOD IS 3/4" THICK AND INSIDE MEASUREMENTS ARE 1" SMALLER ALL THE WAY AROUND
3. LID IS 1/2" LARGER ALL THE WAY AROUND

NOT TO SCALE

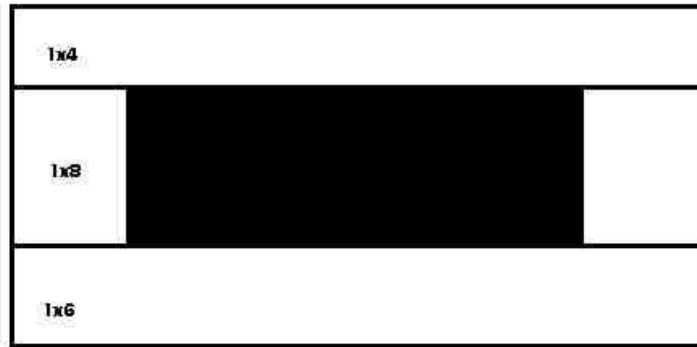
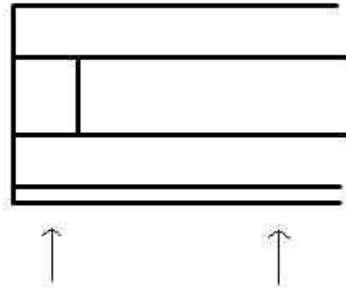
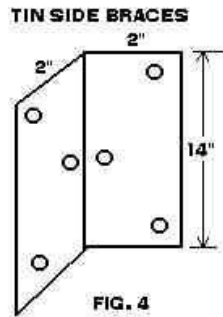

FIG. 1 CONSTRUCTION OF SIDE FRAMES

